



Please read and save these instructions. Read carefully before attempting to assemble, install, operate or maintain the product described. Protect yourself and others by observing all safety information. Failure to comply with instructions could result in personal injury and/or death. Retain instructions for future reference. Assembly and installation of the adjustable safety gate can be inherently dangerous. Take all precautions necessary during assembly and installation.

# Cotterman® Adjustable Safety Gate

## TOOLS NEEDED

7/16" (11 mm) Wrench (2)



9/16" (14 mm) Wrench



3/4" (19 mm) Wrench (2)



Rubber Mallet



Safety Glasses

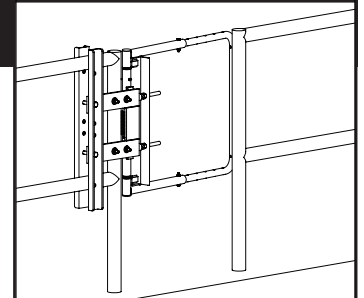

## PARTS

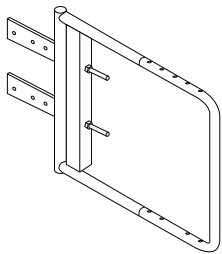

Gate with Adjustment Bolts x 1

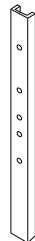

Torsion Bar x 2

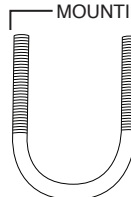

Rounded U-Bolt x 2

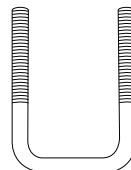

Square U-Bolt x 2

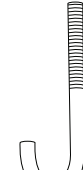

J-Bolt x 2

## Hardware Package



3/8" Flat Washer x 4



3/8-16 Hex Locknut x 4



1/2-13 Flat Hex Locknut x 4

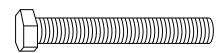

Hex Head Cap Screw x 2

## INSTALLATION



**DANGER!** Death or serious injury may occur if improperly installed or used.

- Installation can be dangerous.
- Read all instructions thoroughly before installing.
- Gate must be installed to prevent unintended passage or fall into elevation change or other hazard.
- Gate must not open toward the elevation change or other hazard.
- Gate must fully close automatically.
- Only install gate on metal safety railing systems that comply with OSHA 1910, ANSI A1264 and other applicable standards for guardrails.
- ONLY install in application where the top of the tube panel is 41" or higher.
- Take necessary precautions during the mounting process.
- Do not fully tighten mounting bolts until instructed to do so.

### SAFETY RAILING MOUNTING (Figures 1-2)

1. Select the proper mounting bolt to attach the mounting plate to the safety railing vertical post: Use round U-bolts for round post, J-bolts for angle post and square U-bolts for square post.



**DANGER!** Death or serious injury may occur if improperly installed or used. Mounting plate **MUST** be placed on opposite side of railing post from mounting bolts.

2. Mount gate so the top gate sleeve is at the same height as the safety railing top. (See Figures 1-2)
3. Place mounting bolts around the safety railing vertical post with threaded ends inserted through the mounting plate holes.
4. Secure mounting bolts with washers and locknuts. (See Figure 1)

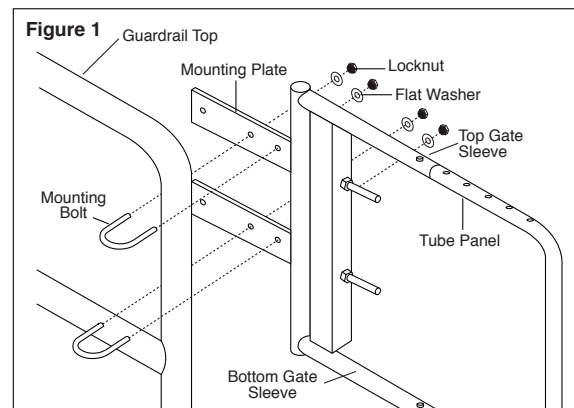
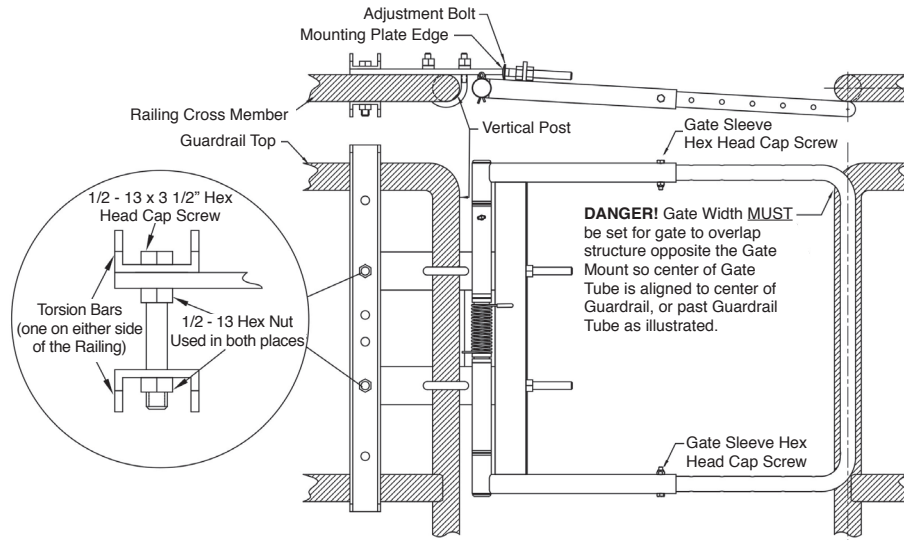

Figure 2



### TORSION BAR ATTACHMENT

1. Torsion bars are required when mounting the gate to a safety railing system.
2. Install torsion bars on both sides of railing with the hex head cap screws and locknuts. (See Figures 2-3)

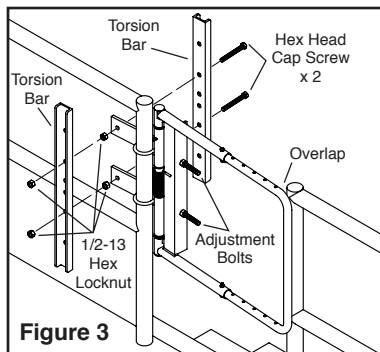

Figure 3

### TIGHTEN MOUNTING BOLTS

1. Fully tighten all mounting bolts and nuts.
2. Test gate to make sure it opens fully and automatically closes completely.
3. If mounting bolt ends interfere with normal operation of gate, trim bolt ends to approximately 1/4" from locknut with hacksaw or cut-off wheel and deburr.



**DANGER! A fall resulting in DEATH or SERIOUS INJURY may occur if gate is improperly installed or used. Gate must be installed to prevent unintended passage or fall into elevation change or other hazard. Gate must not open towards the elevation change or other hazard.**

### ADJUSTING GATE POSITION

1. Hold gate in correct closed position as illustrated in Figure 2.
2. Loosen the nuts on the adjustment bolts and position adjustment bolts until the heads are snug against mounting plate edge. (See Figure 2)
3. Re-tighten the nuts on adjustment bolts. Open gate and let close. Make sure gate fully closes automatically and stops in closed position as illustrated in Figure 2.



**DANGER! A fall resulting in DEATH or SERIOUS INJURY may occur if gate is improperly installed or used. Do not set adjustment bolts to hold gate open. Do not prop gate open, or otherwise impede proper operation of the gate. Gate must fully close automatically.**

### GATE WIDTH ADJUSTMENT



**DANGER! A fall resulting in DEATH or SERIOUS INJURY may occur if gate is improperly installed or used. Gate width MUST be set for gate to overlap structure opposite the gate mount so center of gate tube is aligned to center of guardrail or past guardrail tube, as illustrated in Figures 2 and 3. Gate width is adjustable in two inch increments.**

1. Remove gate sleeve hex head cap screws and locknuts from gate sleeve and tube panel.
2. Slide gate tube panel in or out to set position.
3. Align holes in gate tube panel and gate sleeve.
4. Replace cap screws through aligned holes.
5. Replace locknuts and fully tighten.



**DANGER! A fall resulting in DEATH or SERIOUS INJURY may occur if gate is improperly installed or used. Do not use gate unless gate tube panel and the cap screws are in place and locknuts are securely tightened.**

MAINTENANCE

Inspect gate for any permanent deformation, corrosion, degradation, failure of the gate to fully close automatically, or any condition impairing protective capability.



**DANGER! A fall resulting in DEATH or SERIOUS INJURY may occur if gate is improperly installed or used. If any of the conditions are suspected, barricade from use with warnings prohibiting use prominently displayed until gate can be replaced.**

QUESTIONS OR INQUIRIES SHOULD BE DIRECTED TO:

**COTTERMAN COMPANY**

DIVISION OF MATERIAL CONTROL, INC.

P.O. BOX 168

CROSWELL, MICHIGAN 48422

PHONE: (810) 679-4400

FAX: (810) 679-4510

E-MAIL: [info@cotterman.com](mailto:info@cotterman.com)